

Note: MARK is -3V or less on U101-8, +5V on U101-9, ground on Q100-C, and current flow in TTY loops.

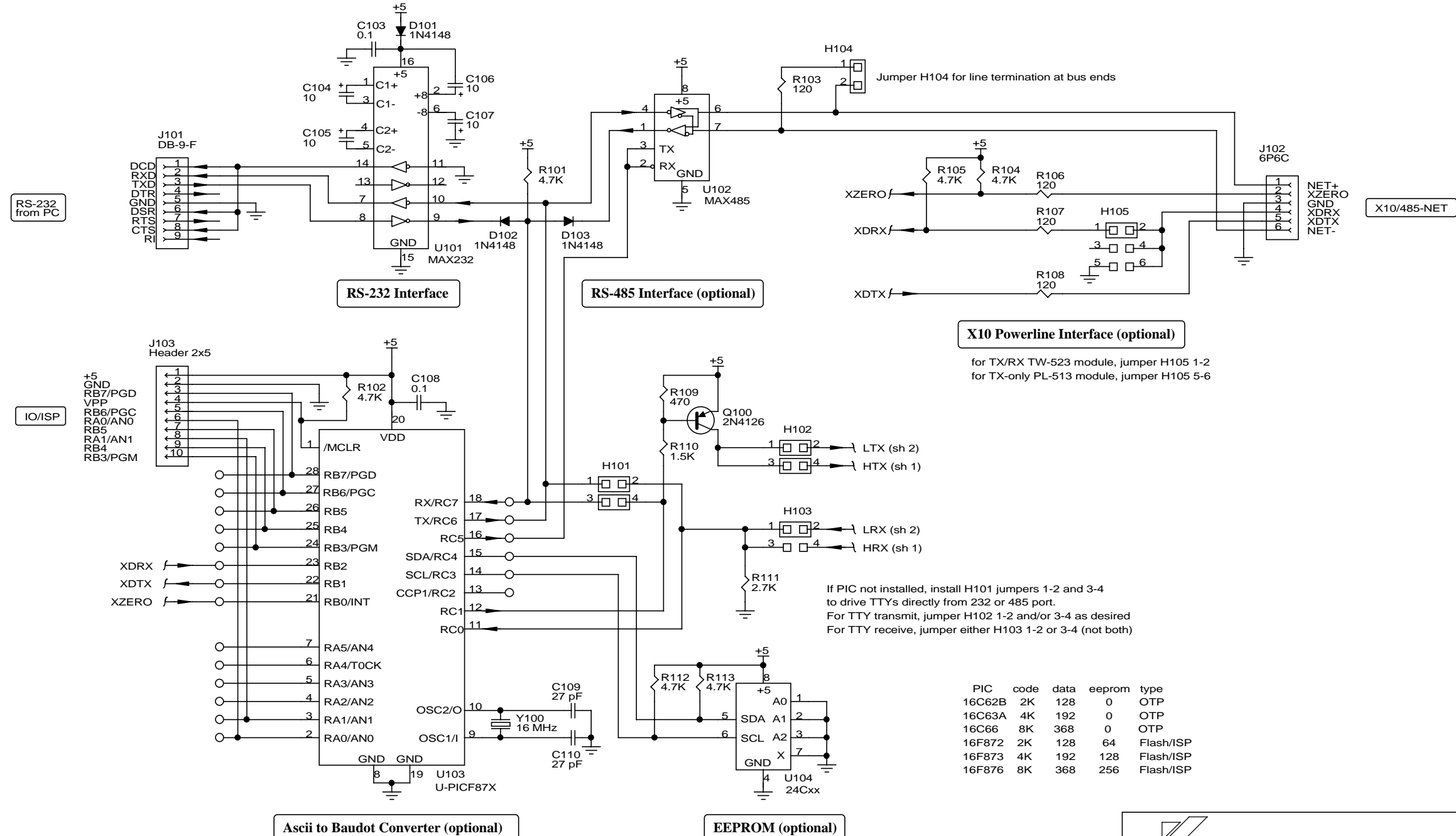

X10 Powerline Interface (optional)
 for TX/RX TW-523 module, jumper H105 1-2
 for TX-only PL-513 module, jumper H105 5-6

If PIC not installed, install H101 jumpers 1-2 and 3-4 to drive TTYs directly from 232 or 485 port.
 For TTY transmit, jumper H102 1-2 and/or 3-4 as desired
 For TTY receive, jumper either H103 1-2 or 3-4 (not both)

PIC	code	data	eeeprom	type
16C62B	2K	128	0	OTP
16C63A	4K	192	0	OTP
16C66	8K	368	0	OTP
16F872	2K	128	64	Flash/ISP
16F873	4K	192	128	Flash/ISP
16F876	8K	368	256	Flash/ISP